



Cambridge IGCSE™

CANDIDATE
NAME

--

CENTRE
NUMBER

--	--	--	--	--

CANDIDATE
NUMBER

--	--	--	--

* 0 1 2 3 4 5 6 7 8 9 *

COMBINED SCIENCE

0653/05

Paper 5 Practical Test

For examination from 2025

SPECIMEN PAPER

1 hour 15 minutes

You must answer on the question paper.

You will need: The materials and apparatus listed in the confidential instructions

INSTRUCTIONS

- Answer **all** questions.
- Use a black or dark blue pen. You may use an HB pencil for any diagrams or graphs.
- Write your name, centre number and candidate number in the boxes at the top of the page.
- Write your answer to each question in the space provided.
- Do **not** use an erasable pen or correction fluid.
- Do **not** write on any bar codes.
- You may use a calculator.
- You should show all your working and use appropriate units.

INFORMATION

- The total mark for this paper is 40.
- The number of marks for each question or part question is shown in brackets [].
- Notes for use in qualitative analysis are provided in the question paper.

This document has **14** pages. Any blank pages are indicated.

1 You are going to investigate vitamin C in apple juice.

You are provided with half an apple and some apple juice.

(a) In the box, make a large drawing of the cut surface of the apple.



[3]

(b) You will test the apple juice using DCPIP.

DCPIP is a dark blue solution that turns colourless when vitamin C is added.

The greater the amount of vitamin C in the apple juice, the fewer the drops of apple juice needed to turn the DCPIP colourless.

(i) **Procedure**

- Use a pipette to put 4 drops of DCPIP into each of three test-tubes.
- Use a clean pipette to add drops of apple juice to one of the test-tubes until the solution becomes colourless. Count the number of drops as you add them.
- Record the number of drops added. This is experiment **1**. Record your results in Table 1.1.
- Repeat with the other two test-tubes (experiment **2** and experiment **3**) and record your results in Table 1.1.

Table 1.1

experiment	number of drops of apple juice added
1	
2	
3	

[2]

(ii) Calculate the average number of drops of apple juice added for the three experiments.

average number of drops = [1]

(iii) Suggest **one** limitation of using a pipette in this procedure.

.....
 [1]

[Total: 7]

- 2 When an aquatic plant is exposed to light, it produces bubbles of oxygen gas.

Plan an investigation to determine the relationship between light intensity and the volume of oxygen gas produced by the aquatic plant.

You are provided with the apparatus shown in Fig. 2.1.

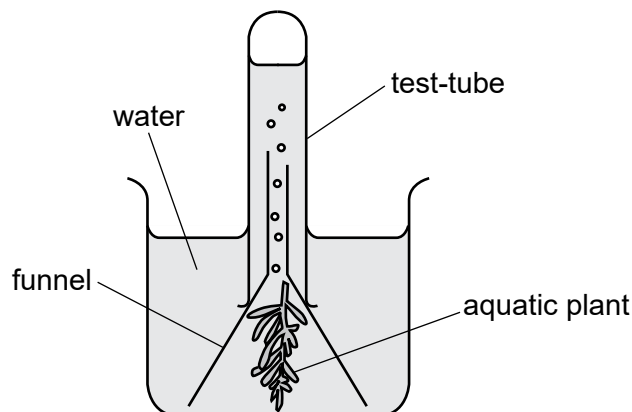

Fig. 2.1

You may use any other common laboratory apparatus in your plan.

You are not required to do this investigation.

In your plan, include:

- any **additional** apparatus and chemicals that you will use
- a brief description of the method, explaining any safety precautions you will take
- what you will measure
- which variables you will control
- how you will process your results to form a conclusion.

You may include a labelled diagram.

You may include a results table (you are not required to enter any readings in the table).

3 You are going to investigate the reaction between metal **F** and dilute sulfuric acid.

(a) Procedure

- Add 3 cm depth of dilute sulfuric acid to a clean test-tube.
- Add a spatula of metal **F** to the test-tube.
- Test the gas produced in the reaction to identify it.

(i) State the test used to identify the gas and give the observation for a positive result.

test

observation

[1]

(ii) State the name of the gas.

..... [1]

(b) Procedure

- Set up the apparatus as shown in Fig. 3.1.

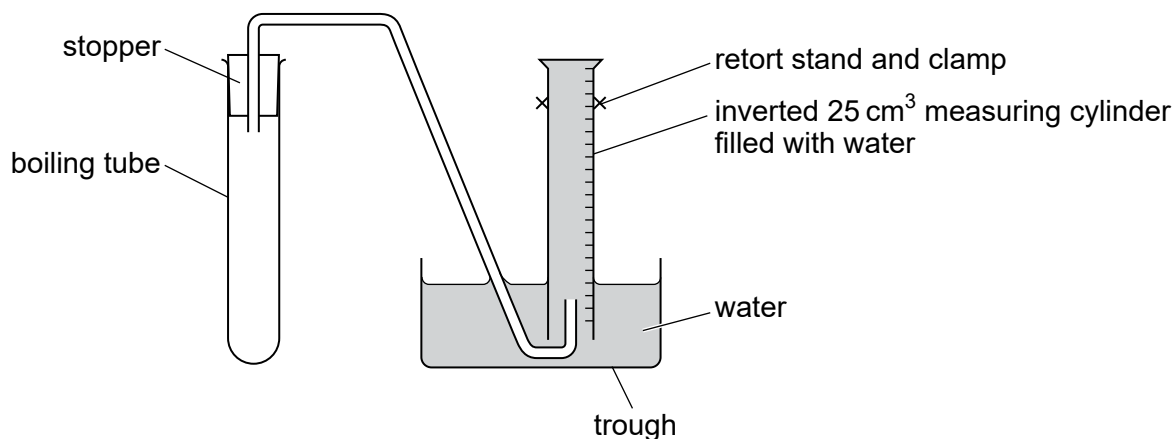
**Fig. 3.1**

- Use the 10 cm³ measuring cylinder to measure 10 cm³ of dilute sulfuric acid.
 - Remove the stopper from the boiling tube.
 - Add the dilute sulfuric acid to the boiling tube.
 - Add about 1 cm³ of aqueous copper(II) sulfate to the boiling tube.
 - Add a spatula of metal **F** to the boiling tube.
 - Put the stopper back into the boiling tube and start the stop-watch.
- (i) Record in Table 3.1 the time taken to collect 5 cm³, 10 cm³, 15 cm³, 20 cm³ and 25 cm³ of gas.

Record each time to the nearest second.

Table 3.1

volume of gas collected / cm ³	time taken / s
5	
10	
15	
20	
25	

[3]

- (ii) State the independent variable and the dependent variable in this investigation.

independent variable

dependent variable

[1]

(iii) On the grid, plot a graph of volume of gas collected (vertical axis) against time taken.

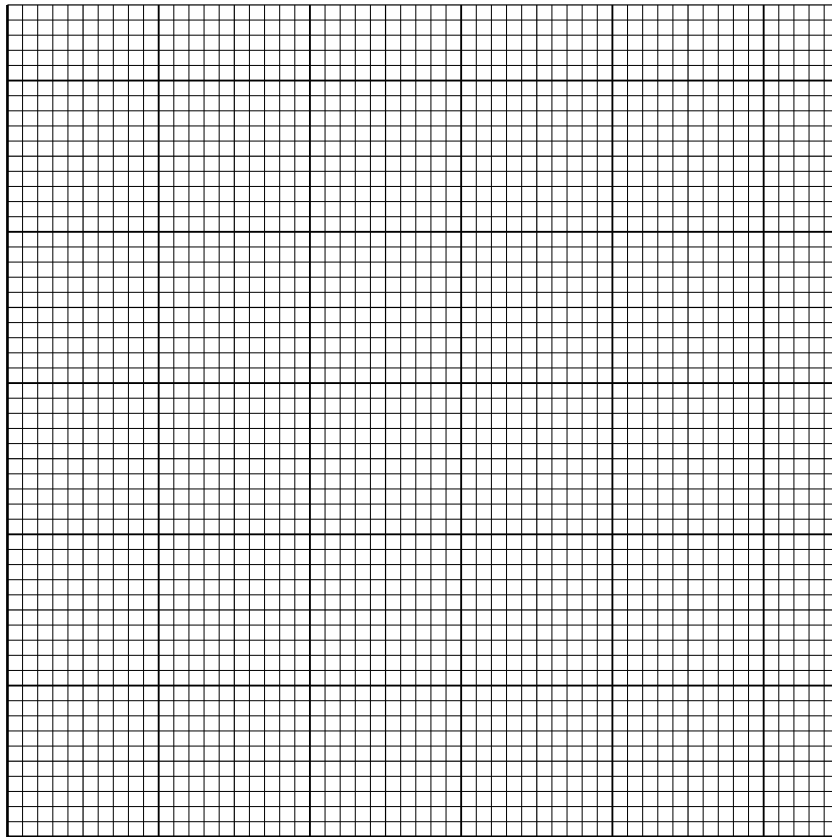

[3]

(iv) Draw the line of best fit.

[1]

(v) Describe the relationship between the volume of gas collected and the time taken.

.....
..... [1]

(vi) Suggest **one** possible source of error in the measurement of the time taken.

.....
..... [1]

(vii) Suggest **one** way to obtain a more accurate measurement of the volume of gas collected.

.....
..... [1]

[Total: 13]

4 You are going to determine the density of the material used to make a metre rule.

(a) Fig. 4.1 shows the length L , width w and thickness t of a metre rule.

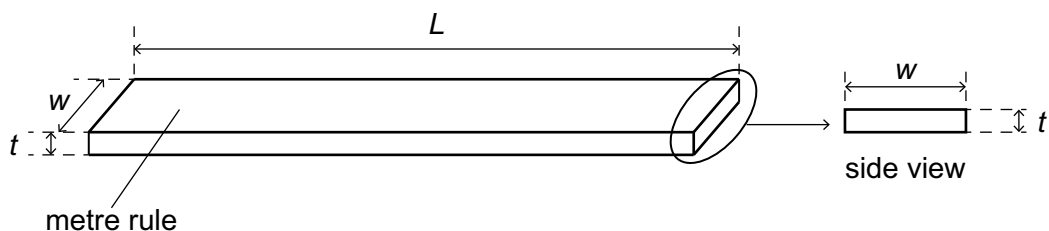

Fig. 4.1 (not to scale)

(i) Use the ruler to measure the width w and thickness t of your metre rule.

Record each measurement to the nearest 0.1 cm.

$w =$ cm

$t =$ cm
[2]

(ii) The measurements in (a)(i) are recorded to the nearest 0.1 cm.

State why it is **not** appropriate to record the measurements to the nearest 0.01 cm.

.....
..... [1]

(iii) The length L of the metre rule is 100.0 cm.

Calculate the volume V of the metre rule.

Use your answers to (a)(i) and the equation shown.

$$V = L \times w \times t$$

$V =$ cm³ [1]

(b) You are going to determine the mass M of the metre rule using a balancing method.

(i) **Procedure**

step 1 Place the pivot directly under the 60 cm mark on the metre rule.

Fig. 4.2 shows distance $d = 60.0$ cm.

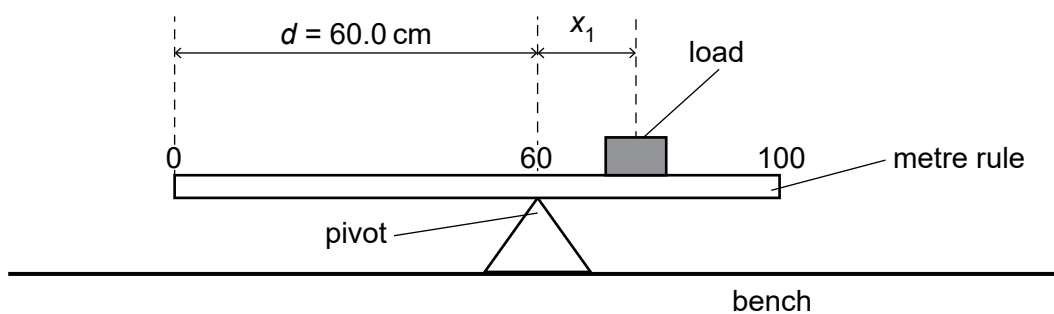

Fig. 4.2

step 2 Place the load on the metre rule.

step 3 Adjust the position of the load until the metre rule is as close to balance as possible.

Measure distance x_1 from the **centre** of the load to the pivot.

$x_1 = \dots\dots\dots$ cm [1]

(ii) **Procedure**

step 4 Remove the load.

step 5 Move the pivot to directly underneath the 70 cm mark so that distance $d = 70.0$ cm.

step 6 Repeat **step 2** and **step 3** in (b)(i).

Measure distance x_2 from the **centre** of the load to the pivot.

$x_2 = \dots\dots\dots$ cm [2]

(iii) Use your results for (b)(i) and (b)(ii) to calculate the mass M of the metre rule.

Use the equation shown.

$$M = 5 (x_1 + x_2)$$

$$M = \dots\dots\dots \text{ g [2]}$$

(iv) State **one** practical difficulty involved in using this method to determine M .

.....
 [1]

(c) Use your answers to (a)(iii) and (b)(iii) to calculate the density ρ of the material used to make the metre rule.

Use the equation shown.

$$\rho = \frac{M}{V}$$

Give your answer to **two** significant figures.

Give the unit for your answer.

$$\rho = \dots\dots\dots$$

$$\text{unit} = \dots\dots\dots \text{ [3]}$$

[Total: 13]

NOTES FOR USE IN QUALITATIVE ANALYSIS

Tests for anions

<i>anion</i>	<i>test</i>	<i>test result</i>
carbonate, CO_3^{2-}	add dilute acid, then test for carbon dioxide gas	effervescence, carbon dioxide produced
chloride, Cl^- [in solution]	acidify with dilute nitric acid, then add aqueous silver nitrate	white ppt.
bromide, Br^- [in solution]	acidify with dilute nitric acid, then add aqueous silver nitrate	cream ppt.
iodide, I^- [in solution]	acidify with dilute nitric acid, then add aqueous silver nitrate	yellow ppt.
sulfate, SO_4^{2-} [in solution]	acidify with dilute nitric acid, then add aqueous barium nitrate	white ppt.

Tests for aqueous cations

<i>cation</i>	<i>effect of aqueous sodium hydroxide</i>	<i>effect of aqueous ammonia</i>
ammonium, NH_4^+	ammonia produced on warming	–
calcium, Ca^{2+}	white ppt., insoluble in excess	no ppt. or very slight white ppt.
copper(II), Cu^{2+}	light blue ppt., insoluble in excess	light blue ppt., soluble in excess, giving a dark blue solution
iron(II), Fe^{2+}	green ppt., insoluble in excess, ppt. turns brown near surface on standing	green ppt., insoluble in excess, ppt. turns brown near surface on standing
iron(III), Fe^{3+}	red-brown ppt., insoluble in excess	red-brown ppt., insoluble in excess
zinc, Zn^{2+}	white ppt., soluble in excess, giving a colourless solution	white ppt., soluble in excess, giving a colourless solution

Tests for gases

<i>gas</i>	<i>test and test result</i>
ammonia, NH_3	turns damp red litmus paper blue
carbon dioxide, CO_2	turns limewater milky
chlorine, Cl_2	bleaches damp litmus paper
hydrogen, H_2	'pops' with a lighted splint
oxygen, O_2	relights a glowing splint

Flame tests for metal ions

<i>metal ion</i>	<i>flame colour</i>
lithium, Li^+	red
sodium, Na^+	yellow
potassium, K^+	lilac
copper(II), Cu^{2+}	blue-green

Permission to reproduce items where third-party owned material protected by copyright is included has been sought and cleared where possible. Every reasonable effort has been made by the publisher (Cambridge University Press & Assessment) to trace copyright holders, but if any items requiring clearance have unwittingly been included, the publisher will be pleased to make amends at the earliest possible opportunity.

Cambridge Assessment International Education is part of Cambridge University Press & Assessment. Cambridge University Press & Assessment is a department of the University of Cambridge.